



**CVap®**  
**HOV**  
class series 5

series 5 holding cabinets with CVap® technology

# OWNER'S MANUAL

**HOV5**

- HOV5-04HP
- HOV5-04UV
- HOV5-05SP
- HOV5-05UV
- HOV5-14SP
- HOV5-14UV



2345 Carton Drive | Louisville, Kentucky 40299 USA  
winstonfoodservice.com | 800.234.5286 | +1.502.495.5400

SERIAL #:



## Warnings

### MISUSE AND OTHER

#### **! WARNING:** Contamination Hazard

Can cause serious illness or damage to equipment >> Clean equipment daily to avoid potential contamination hazard.

Ensure safe operation by cleaning equipment daily. Failure to do so can allow harmful deposits to develop, increasing the potential for food contamination and endangering your customers.

#### **! DANGER:** Electrical Hazard and Burn Hazard

Can cause serious injury or death >> Do not attempt to service this equipment unless you are a licensed electrician or trained servicer.

This equipment uses high voltage electrical systems, high temperature heating systems, and hot water vapor. If used improperly, any of these hazards are capable of causing serious injury or death. To avoid the potential for an accident, please have equipment serviced only by a trained servicer. Please make this page available to the servicer.

#### **! CAUTION:** High Temperature and Grease Hazard

Can cause damage to equipment >> Avoid placing equipment near high heat or in grease-laden atmosphere.

#### **! WARNING:** Safety Hazard, Intended Use

Can cause serious illness or damage to equipment >> Supervise untrained, young, or handicapped persons.

1. This equipment is not intended for use by persons (including children) with reduced physical, sensory, or mental capabilities, or lack of experience and knowledge, unless they have been given supervision or instruction concerning use of the equipment by a person responsible for their safety.
2. Children should be supervised to ensure that they do not play with the equipment.
3. This equipment is intended to be used for commercial applications, for example in kitchens of restaurants, canteens, hospitals and in commercial enterprises such as bakeries, butcheries, etc., but not for continuous mass production of food.

#### **! CAUTION:** High Temperature Hazard

Can cause damage to equipment >> Fill evaporator with water prior to turning power on, and do not allow evaporator to run dry.

#### **MAKE CERTAIN EVAPORATOR HAS AN ADEQUATE SUPPLY OF WATER PRIOR TO TURNING ON POWER SWITCH. WATER LEVEL SHOULD BE APPROXIMATELY AT FILL LINE.**

KEEP DOOR(S) CLOSED WHEN NOT IN USE. If food temperature becomes too low during serving period, increase VAPOR TEMP setting by 10-20° F (11-17° C) to maintain desired food temperature.

#### **! WARNING:** Burn Hazard

To avoid scalding, do not use loaded containers with liquids or cooking goods which becomes fluid by heating in higher levels than those which can be easily observed.

#### **! WARNING:** Burn Hazard

When opening the door of the cooking compartment hot steam can come out.

#### **! DANGER:** Electrical Hazard

If supply cord is damaged, it must be replaced by the manufacturer, its service agent, or similarly qualified persons in order to avoid a hazard.

## Warranty & Terms and Conditions of Sale

Limited one-year warranty (excluding gaskets, lamps, hoses, power cords, glass panels, fryer baskets, batteries, and evaporators). Warranty disclaimer for failure to clean.

WINSTON EXPRESSLY DISCLAIMS ALL OTHER WARRANTIES, EITHER EXPRESS OR IMPLIED, INCLUDING ANY IMPLIED WARRANTY OF FITNESS FOR A PARTICULAR PURPOSE AND ANY IMPLIED WARRANTY OF MERCHANTABILITY.

For complete details on warranty and terms & conditions of sale, go to: [https:// bit.ly/2Qzwi6G](https://bit.ly/2Qzwi6G) Both the Warranty and Terms and Conditions of Sale are integral to this document.



## Requirements

### GENERAL INSTALLATION

Install equipment on a solid, flat, level surface in a location where ambient temperatures will not exceed 100° F and away from grease laden vapors from other equipment. For proper ventilation of the equipment, allow 2-inch clearance on all sides, particularly around any ventilation holes. Plug the equipment into a properly grounded outlet of the correct voltage and phasing as indicated by the equipment ID labels. *Please read the installation instructions that follow.*

#### water

If manually filling equipment with water, fill evaporator pan with approximately 2.5 gallons of water, unless it is a 04-HP unit. 04-HP units require 1.25 gallons of water. As water evaporates, minerals in the water will deposit on the surface of the evaporator. These mineral deposits will inhibit the transfer of heat. Deposits can also degrade and damage stainless steel. To avoid mineral deposits clean the equipment daily. It is advisable to contact your water utility for advice on minimizing deposit buildup.

#### CAUTION:

##### High Temperature Hazard

Can cause damage to equipment >>  
If utilizing vapor heat, fill evaporator with water prior to turning power on and do not allow evaporator to run dry.

For locations with hard water, add one tablespoon (15 ml) of white vinegar or lemon juice to water to help minimize scale buildup. Please consider contacting your local water authority to obtain advice on possible water treatments to protect the equipment. Some water supplies are high enough in chemical content to be capable of damaging stainless steel (if used untreated). The evaporation process can concentrate the chemicals in the water to a level which could cause a damaging reaction with the stainless steel.

#### ventilation

**Ventilation Clearances:** To operate properly, the equipment will need sufficient space for air circulation. Allow at least 2" (51 mm) clearance on all sides, particularly around ventilation holes. Care should be taken to prevent placing the equipment close to anything combustible. It must be installed with its supplied casters or legs. Equipment may be stacked upon each other using only a Winston supplied stacking kit and following the instructions enclosed with the kit. Your warranty may be void if you do not adhere to these ventilation requirements.

#### CAUTION:

##### High Temperature & Grease Hazard

Can cause damage to equipment >>  
Avoid placing equipment near high heat or in grease-laden atmosphere.

Do not place equipment in an area where ambient temperature (air temperature around the equipment) exceeds 100° F (38° C). A heat shield may be required to prevent excessive heat exposure and grease-laden vapors from affecting the equipment if adjacent to heat, vapor, or grease generating devices (such as grills, steamers, ovens, etc.). Excess heat and grease inside the equipment cavities may cause electrical components to fail.

**Vent Hood:** Generally this equipment does not need to be installed under a mechanical ventilation system (vent hood). Check local health and fire codes for requirements specific to your location.

#### auto water fill

Automatic water fill is available as an optional feature. Auto water fill systems must be hooked up to a potable water supply line. **The water supply line must be flushed of any debris before connecting to unit. Failure to do so can damage the water solenoid.** The maximum incoming water temperature may not exceed 140° F (60° C) and the incoming water pressure must be between 20 and 150 psi (137.9 kPa to 1034 kPa). Equipment with auto water fill systems **MUST NOT BE ALLOWED TO RUN DRY.** Heat damage to the water solenoid may result.

It is the responsibility of the owner and installer to ensure that installation complies with all local and state plumbing codes.

#### shelving

The load limit per rack is 65 lbs (29.25kg).

## Contact Information

Internet: <https://foodservice.winstonind.com/>

E-mail: [customercare@winstonind.com](mailto:customercare@winstonind.com)

Phone: 800.234.5286 | +1.502.495.5400

Fax: +1.502.495.5458

Mail: 2345 Carton Drive | Louisville, KY 40299 USA

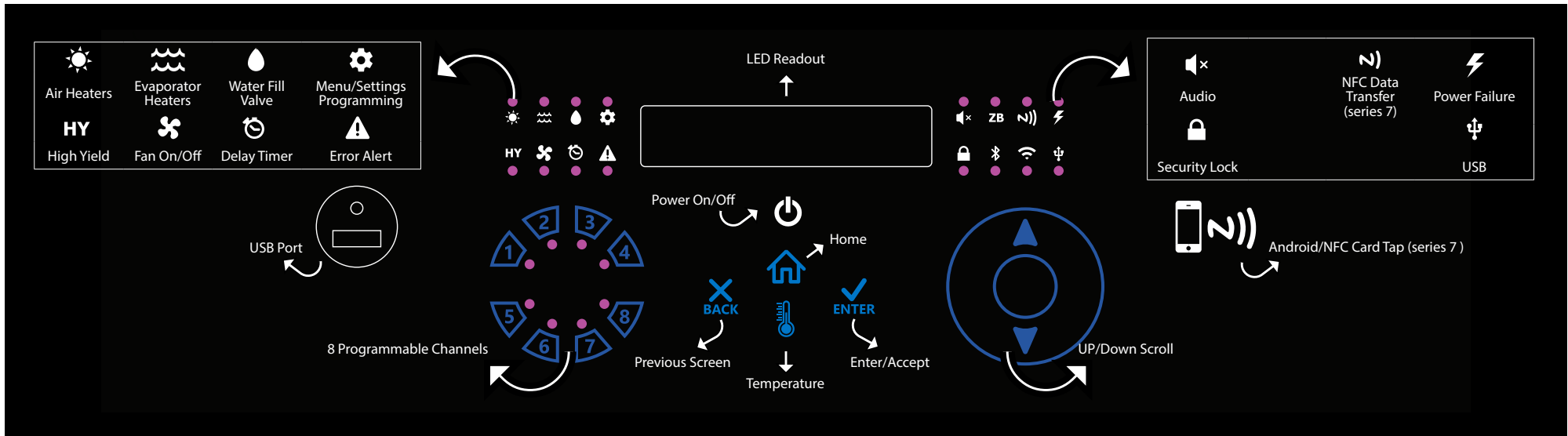

## New Winston CVap: Control Programming

### START-UP BASICS

**H<sub>2</sub>O** Does your unit have WATER filled to the fill line?



Push the power button to turn unit On.

Push the power button at any time to turn the unit Off.

### THE TOUCH WHEEL

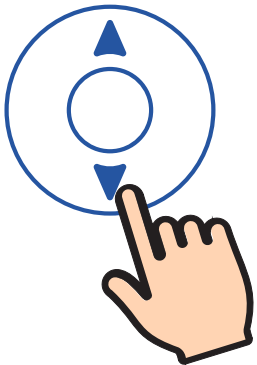

Place your finger on the up or down button to choose between all of your options.

When you select the option to use, always press ENTER to continue.

### QUICK USE

#### Cook & Holds (CHV), Holding Cabinets (HOV) or Retherm Ovens (RTV)

1. After the unit is filled with water, turn it On.
2. Select the preset channel you want. Unit will read PREHEAT.
3. When unit reads HEATED, put food into oven and press ENTER.
4. When you are done, tap the channel again to exit.

#### Helpful Tips - Selecting Channel

1. If the incorrect channel was selected prior to starting a cycle, the channel may be changed by tapping the illuminated channel number and selecting an alternate channel.
2. If you desire to stop the cycle during a hold, you may either press the illuminated channel or the back key to exit channel, then press ENTER.

## Main Menu

- **View Channel** - Select this to see what my settings are on any channel.
- **Program Channel** - Select this to program each channel.
- **Delay Start** - Prepare ahead by allowing a desired channel to turn on automatically. It can be set for up to a 99-hour delay.
- **Settings** - Allows you to make special adjustments to the unit.
  - o Security - Using the code **2345** locks or unlocks a unit, allowing general daily operation only.
  - o Volume - Adjust the volume of the speakers.
  - o Display - Adjust the display temperature readout to show air temperature or evaporator.
  - o Temperature Scale - Adjust between Fahrenheit or Celsius.
  - o Time and Date - Set up a calendar in the unit to allow for accuracy with HACCP downloads.
  - o Fill System - Adjust setting for Water Level Sensor (disabled, probe, or float) and Water Valve (disabled or enabled).
  - o Tuning - Calibrates vapor temperature for the size and model of the unit, for maximum precision.
- **USB** - Pull HACCP temperature data, upload settings, or perform software updates.
- **About** - Informs the user of software versions during troubleshooting needs.
- **Reboot** - Allows unit to be rebooted

## Preprogrammed Channels

### HOLDING CABINET

#### Channel 1: Soft Hold - *Inf/155/155/ConvOn*

- Pastas, Vegetables, Etc.

#### Channel 2: Medium Hold - *Inf/150/165/ConvOn*

- Meats, Soft Breads, etc.

#### Channel 3: All Purpose Hold - *Inf/150/180/ConvOn*

- Mix of Products

#### Channel 4: Crisp Hold - *Inf/130/180/ConvOn*

- Breaded/Fried Products

#### Channel 5: Gentle Hold - *Inf/133/136/ConvOn*

- Rare-MR Steaks, Seafood, etc.

#### Channel 6: Firm Hold 2 - *Inf/150/155/ConvOn*

- Meats, Soft Breads, Etc.

#### Channel 7: Crisp Hold 2 - *Inf/120/190/ConvOn*

- Breaded/Fried Products

#### Channel 8: Super Crisp Hold - *Inf/90/180/ConvOn*

- Fried/Dried Products

## Food Holding Reference Chart

Product	Vapor Temperature	Air Temperature
Soft Moist Foods Sauces, gravies, vegetables, fish, etc.	140 to 155° F (60 to 68° C)	140 to 155° F (60 to 68° C)
Firm Moist Foods Bakery, meats, chicken, etc.	140 to 155° F (60 to 68° C)	145 to 185° F (63 to 85° C)
Crisp Foods Fried or breaded products	130 to 150° F (50 to 66° C)	170 to 200° F (77 to 93° C)
Very Crisp Foods Tortilla chips, fries, etc.	Off to 130° F (Off to 50° C)	180 to 200° F (82 to 93° C)

## Program Channels

### USING CONTROL

1. Use touch wheel and select **Program Channel**...then press ENTER.
2. When unit reads **Select Channel**, pick which number you want to save to (1-8).
3. Use touch wheel to adjust alarm for **Holding Time**. Your options are **Infinite** (no alarm) or :01-99:00, then press ENTER. If you do not wish to use an alarm, set to Infinite.
4. Use touch wheel to adjust **Holding Vapor Temperature**. Your options are **Off** or **90-200 °F** (off or 32-93 °C), then press ENTER.
5. Use touch wheel to adjust **Holding Air Temperature**. Your options are **Off**, or **up to 205°F** (96 °C), then press ENTER.
6. Use touch wheel to adjust **Convection Holding**. Your options are **On** or **Off**, then press ENTER. (**series 7 only**)
7. Unit saves your settings and then goes back to **Home Screen**.

## Updating Firmware

1. Power your cabinet on. The current firmware version will scroll across the screen when booting up.
2. Go to <https://foodservice.winstonind.com/firmware-updates/> to determine if the current version is installed.
3. Follow instructions to update your firmware, if needed.

## Downloading HACCP Records

1. Insert USB stick
2. Use dial to navigate to "USB" heading and press ENTER key.
3. Under the "USB" heading, use the dial to choose, "DOWNLOAD HACCP RECORD" and press ENTER.
4. The display will read, "DOWNLOADING" and the USB indicator will flash.
5. Upon completion the control will return to the menu and the display will read, "DOWNLOAD HACCP RECORDS".
6. Remove USB stick.

### *Helpful Tips - Programming Channel Using Control*

1. At any time after selecting enter, you can press the HOME button to end the programming. Anything selected by pressing ENTER will already be saved.
2. At any time during the programing, you may press BACK to go to the previous options.

## Procedures

### DAILY CLEANING

#### Required Cleaning Accessories & Supplies

- Pan for draining evaporator
- Food grade germicidal detergent
- Descaling agent

**! CAUTION: Corrosion Hazard**  
Can cause damage to equipment >>  
Clean unit daily to avoid potential corrosion damage.

Clean evaporator daily to prevent chlorides (salts) from accumulating. Chlorides can cause the evaporator tank to corrode to the extent that leaks can occur. Leaks caused by corrosion, which is caused by a failure to clean daily, are not covered under the manufacturer's warranty.

**! CAUTION: Burn Hazard**  
Can cause serious injury >>  
Allow equipment to cool for at least 30 minutes.

#### cleaning procedure

**Ensure that any chemical used to clean equipment is free of sodium and other ingredients that could be corrosive to metal.**

1. Disconnect power supply. Allow equipment to cool.
2. Place empty pan under drain valve, open drain valve and allow evaporator to drain.
3. Remove and clean rack supports using a food-grade germicidal agent. Rinse and allow to dry.
4. Remove evaporator cover and clean, then allow cover to dry.

5. Spray food chamber and evaporator with a food grade germicidal detergent.
6. Wipe inside surfaces to remove all food deposits.
7. Inspect for scale build-up on the tank surface and probe. If present, apply descaling agent like Citranox. Read ALL warnings and follow directions listed on descaling agent package.





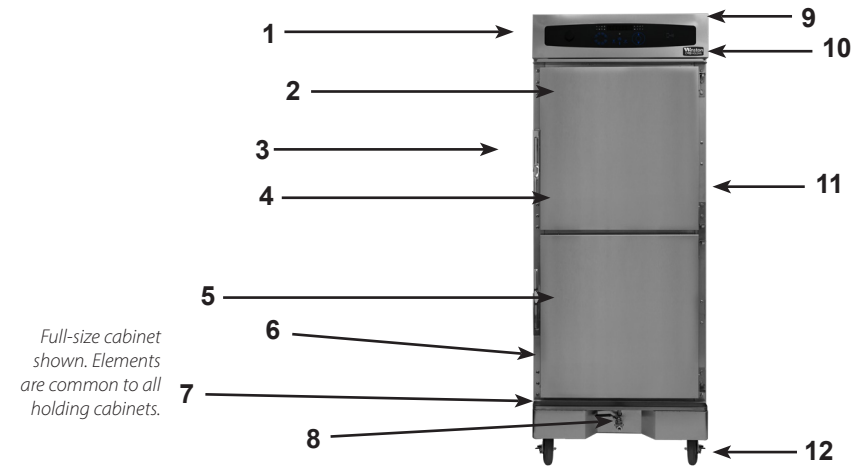

**! DANGER: Electrical Hazard**  
Can cause serious personal injury or damage to the equipment >> Avoid spraying equipment exterior or controls with water.

8. Rinse all inside surfaces, including evaporator, and dry with clean towel. **Do not spray outside of equipment or controls with water.**
9. Replace rack supports.
10. Replace evaporator cover.
11. Close the drain valve.
12. Reconnect equipment to electrical power and make ready for use.

## Component Identification



1. **Control Panel** - contains power button and control escutcheon. Allows operator to program food temperature and food texture. Escutcheon is removable for servicing or replacing microprocessor.
2. **Door Gasket** seals food chamber against heat or vapor loss.
3. **Door & Latch** can be reversed on site.
4. **Adjustable Rails** - located on both sides inside equipment, holds trays, pans, shelves, and racks.
5. **Food Chamber** - holding cavity where the dual heat system combines to create the perfect holding environment.
6. **Evaporator and Heaters** (not visible) - supply vapor atmosphere to the food chamber by heating water within the evaporator.
7. **Trough** collects moisture that condenses on door.
8. **Drain Valve** allows for draining water from evaporator.
9. **Cord Wrap** (behind unit if applicable) provides storage for power cord.
10. **Name Plate** identifies model number, serial number (important for servicing and ordering parts), voltage, power, and electrical information. Electrical Requirements Label identifies that equipment is for use with an individual branch circuit only.
11. **Air Heaters** (not visible) - supply heat for precise food texture control.
12. **Casters** provide easy movement when front casters are in unlocked position.

MODEL #	CAPACITY*			EXTERIOR DIMENSIONS**			ELECTRICAL						SHIP WEIGHT LBS(KG)
	SHEET PAN (18" x 26")	HALF SHEET PAN (18" x 13")	HOTEL PAN (12" x 20" x 2.5")	HEIGHT IN.(MM)	DEPTH IN.(MM)	WIDTH IN.(MM)	VOLTS	PHASE	WATTS	AMPS	NEMA***	INT'L	
HOV5-04HP	N/A	4	4	36.38(924)	26.45(672)	20(508)	120	1	1824	15.20	5-20P 	Call Factory	160 (73)
HOV5-04UV	4	8	8	35.70(907)	34.23(869)	27.70(704)	120	1	2292	19.1	5-20P 	Call Factory	198(90)
HOV5-05SP	5	10	N/A	39.22(996)	34.23(869)	24.70(627)	120	1	2292	19.1	5-20P 	Call Factory	235(107)
HOV5-05UV	5	10	10	39.22(996)	34.23(869)	27.70(704)	120	1	2292	19.1	5-20P 	Call Factory	250(113)
HOV5-14SP	14	28	N/A	73.02(1855)	34.23(869)	24.70(627)	120	1	2292	19.1	5-20P 	Call Factory	394(179)
HOV5-14UV	14	28	28	73.02(1855)	34.23(869)	27.70(704)	120	1	2292	19.1	5-20P 	Call Factory	420(190)

\*Capacity- Determined by 3.5" (89mm) adjustable spacing, with a load limit of 65lb (29.25kg) per rack. | \*\*Exterior Dimensions- Based on use of standard supplied 3" Heavy Duty plate casters. Subtract 2.37" (60mm) for 1" wheels, add 2.14"(54mm) for 5" casters, add 0.17(4mm) for 4" legs, and add 2.17"(55mm) for 6" legs. | \*\*\*NEMA- Supplied with 84" (2134mm) (minimum) power cord and plug. The input average of current did not exceed the allowable amperage for the circuit listed.



CVap<sup>®</sup>  
**HOV**  
class series 5