

SPECIFICATIONS

Short Form Specs

Winston Collectramatic high efficiency pressure fryer, model LP46 or LP56 with 20-channel processor controls and 13" deep collector, which allows up to 360 lbs. of chicken (or equivalent) to be cooked without manual filtration or emptying collector. Utilize quarter rack basket to maintain separation of product during cooking.

Construction

Control Computerized processor control with twenty programmable channels.

Capacity LP46
4 Head - 14 lbs. (6.35 kg) product
64 lbs. (28.8 kg) or 8.15 g (30.85L) cooking oil

LP56
6 Head - 18 lbs. (8.2 kg) product
75 lbs. (33.8 kg) or 9.55 g (36.15L) cooking oil

Electrical Refer to wiring schematic included in equipment for installation assistance. Cord/Plug not included. Shipped wired for 3-phase application. Licensed electrician may be required. Check local codes.

Materials To be 16 - 20 gauge stainless steel mounted on four adjustable legs. Cooking vessel to be constructed of stainless steel.

Insulation Full 1-1/2" insulation around the cooking vessel.

Load Limits Maximum of 14 lbs. (LP46) or 18 Lbs. (LP56) of frozen or refrigerated chicken, fish, meats, or vegetables per load.

Installation Requirements Ventilation required. Check local codes.



LP46 & LP56
COLLECTRAMATIC®
HIGH EFFICIENCY FRYER
20-Channel Programmable Controls



Collectramatic High Efficiency Pressure Fryers are the workhorses of any kitchen and can cook up to 120 deliciously golden-brown fried chickens without filtration.

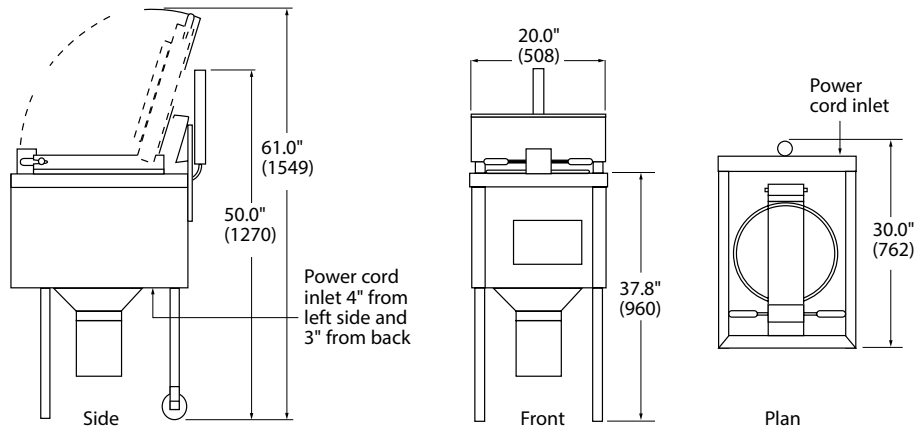

capacity	size in (mm)	volts	hertz	ph	amps	watts	circuit amps	ship wt. lb (kg)	ship cube
US / CANADA									
LP46 4 Head 14 lbs. (6.35 kg) product 64 lbs. (28.8 kg), or 8.15 g (30.85L) cooking oil	H= 50.0" (1270)	208	60	3	29.2	10500	50	190 (86)	20.0 (0.57)
	H2= 61.0" (1549)	240	60	3	25.2	10500	50		
	W= 20" (508) D= 30.0" (762)	240	60	1	43.7	10500	60		
INTERNATIONAL									
		400*	50	3	N/A	10500	N/A	190 (86)	call factory
US / CANADA									
LP56 6 Head 18 lbs. (8.2 kg) product 75 lbs. (33.8 kg), or 9.55 g (36.15L) cooking oil	H= 50.0" (1270)	208	60	3	29.2	10500	50	207 (94) 20.0 (0.57)	
	H2= 61.0" (1549)	240	60	3	25.2	10500	50		
	W= 20" (508) D= 30.0" (762)	240	60	1	43.7	10500	60		
INTERNATIONAL									
		400*	50	3	N/A	10500	N/A	207 (94)	call factory

H= Height w/lid closed • H2= Height w/lid open • Includes: 1 clamshell basket, 1 drain hook, 1 pair gloves, 1 spatula, 2 collector gaskets, 2 lid gaskets, 1 Teflon® brush, 1 long collector, 1 heat plate • Cord and plug not included

OPERATIONAL EXCELLENCE the Collectramatic fryer has the largest cold zone in the industry and can perform 20-30 cook cycles without filtration, which extends shortening life and reduces filtering downtime. If speed of service is important, the fryer's heat curve can be adjusted to cook up to 18 lbs. of fried chicken in as little as ten minutes. Utilizing Winston's Quarter Rack basket system improves labor efficiencies because the chicken is cooked on racks and moved directly into the holding cabinet with minimal handling.

EASY-TO-USE CONTROLS standard to all Collectramatic fryers is a microprocessor control, which never requires calibration for accuracy. Within any of the twenty channels, up to six temperatures and multiple time settings can be programmed per cook cycle. The controller also offers "Flex-Time" for varying sized products and a shortening management system.

BUILT TO LAST WITH QUALITY CRAFTSMANSHIP, the cylindrical cooking pot of the Collectramatic fryer is constructed to last for many years. Each fryer is built with high grade stainless steel and uses very few moving parts.

WARRANTY. Limited one year warranty. Warranty disclaimer for failure to clean. Ask for complete warranty disclosure.

SPECIFY THE FOLLOWING WHEN ORDERING:

Standard (No additional cost):

1. Model number.
2. Voltage Preference: 208V or 240V for US or Canada.
3. Drain Valve Indicator
Cordset is not included.
All units shipped 3-phase.

*Inquire about additional international voltages available.

Standard (No additional cost):

- | | |
|---------------------|------------------|
| 1 Clamshell basket | 1 Drain Hook |
| 2 Collector gaskets | 1 Heat plate |
| 2 Lid gaskets | 1 Teflon® brush |
| 1 Spatula | 1 Long collector |
| 1 Plugging tool | 1 Displacer tool |

Accessories & Supplies (Additional cost):

- | | |
|-----------------------------------|-----------------------------------|
| PS1180 Utensil rack | PS2837/25Qtr rack basket shelves |
| PS2838 Qtr rack basket, 4-hd | PS1290 Open basket |
| PS2839 Qtr rack basket, 6-hd | PS2837/1 Qtr rack basket shelf |
| PS2837/10 Qtr rack basket shelves | PS2837/50 Qtr rack basket shelves |

FOR WINSTON SERVICE PARTS, ACCESSORIES, AND SUPPLIES ONLINE!

foodservice.winstonind.com/parts-supplies



C::LLECTRAMATIC

WINSTON FOODSERVICE

2345 Carton Drive | Louisville, KY 40299 USA
winstonfoodservice.com | 800.234.5286 | +1.502.495.5400

Specifications subject to change without notice.