

## **CVap® Flip Door Holding Cabinets**

CVap Holding Cabinets with flip doors are the latest addition to Winston's holding line. Available in convenient countertop and full sizes, there are configurations to fit every need.

**Easy Refilling  
and Packing**

**Magnetic  
Hinges**



HOV7-14SP  
(Shown with optional  
flip doors and pass-  
through.)

CVap gives you consistent food quality. Our flip door cabinets allow you to pack from the front while keeping food hot.

Flip up doors stay in place to make refilling and boxing easy. Patent-pending magnetic hinges won't wear out over time. See-through doors mean you always know how much inventory is available.



**View Inventory  
at a Glance**

HOV7-05SP  
(Shown with optional  
flip doors and pass-  
through.)



# CVap® Flip Door Holding Cabinets

## HOV7-05SP Spec (with optional flip-doors and pass-through)

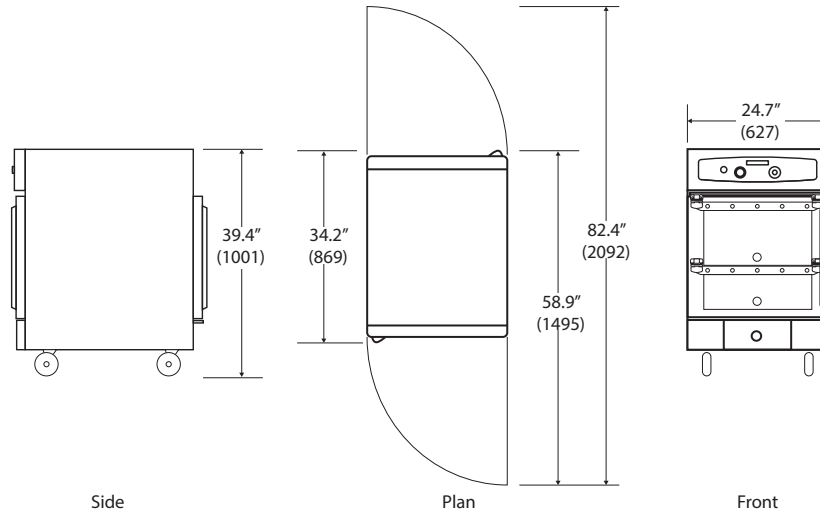

## HOV7-14SP Spec (with optional flip-doors and pass-through)

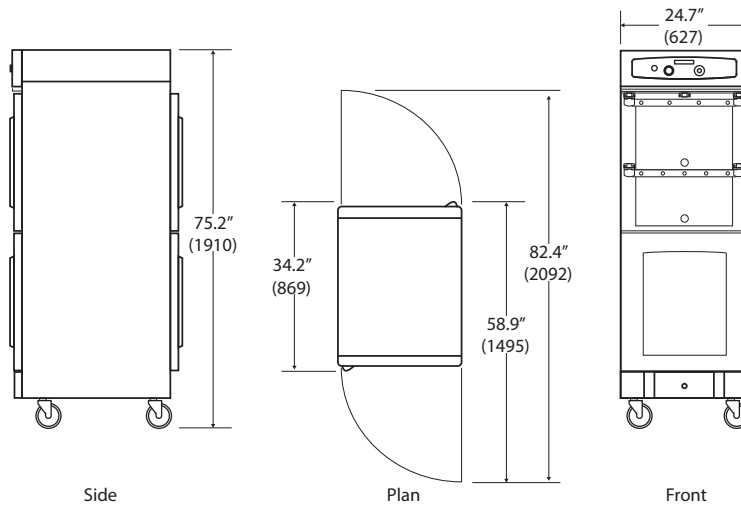

Drawings may not be to scale.

Model #	Capacity		Exterior Dimensions			Electrical					Door Config	
	Sheet Pan (18" x 26")	Half Sheet Pan (18" x 13")	Height IN.(MM)	Depth IN.(MM)	Width IN.(MM)	Volts	Phase	Watts	Amps	NEMA***	Front Door	Rear Door
HOV7-05SP	5	10	39.4(1001)*	34.2(869)	24.7(627)	120	1	2292	19.1	5-20P	Flip Door	Flip Door or Window
						230	1	2292	9.7	***		
HOV7-14SP	14	28	75.2(1909)**	34.2(869)	24.7(627)	120	1	2491	20.76	5-30P	Flip Door or Window Top/ Window Bottom	Flip Door or Window Top/ Window Bottom
						230	1	2491	10.83	***		

Cabinet height is calculated with standard caster size. If 3" caster is standard, subtract 2.48" (63mm) for 1.5" wheels, add 2.31" (59mm) for 5" casters, subtract .25" (6mm) for 4" legs, and add 1.63" (41mm) for 6" legs. If 5" caster is standard, subtract 2.31" (59mm) for 3" casters, and subtract .69" (18mm) for 6" legs.

\*\*\*NEMA- Supplied with 84" (2134mm) (minimum) power cord and plug. The input average of current did not exceed the allowable amperage for the circuit listed.

**WATER FILL:** Low water detection. Auto-fill included. Low mineral potable water recommended, otherwise use deionizer/demineralizer to minimize corrosion damage.

**INSTALLATION REQUIREMENTS:** Units to be installed with 2" (51mm) clearance on sides and may not be installed within proximity to anything emitting heat that would allow the exterior of the Winston cabinet to exceed surface temperatures of >200°F. Refer to owner's manual for specific installation requirements.

**INDUSTRY COMPLIANT:** Equipment complies with domestic and most international requirements; such as UL, C-UL, UL Sanitation, CE, MEA, EPA202, and others.

