

Stacking Kit Installation - PS2428 - CA, HA, 02-03

INSTRUCTION MANUAL

TOOL(S) NEEDED: • Phillips head screwdriver

INSTRUCTIONS:

1. Unplug cabinets to be stacked and allow them to cool down.
2. Remove six screws (save for re-use) from both sides of the cabinet top on the lower cabinet.
3. Install the side brackets by aligning the holes and re-inserting the screws from step #2 into the cabinet top.
4. Install the mid bracket by inserting the 8x1/2 screws (provided) through both side brackets into the ends of the mid bracket.
5. Remove casters from the bottom side of the upper cabinet and discard (you may leave the casters on the cabinet if desired). Remove six screws (save for re-use) from the lower sides of the upper cabinet. Place the upper cabinet firmly in place, aligning the cabinet screw holes with the side brackets. Use same screws to secure the side brackets to the upper cabinet.
6. Insert the end brackets by installing the screws (provided) as shown.
7. Check to ensure all screws are secure and units are sturdy. Plug units back into their power supply and continue normal operation.

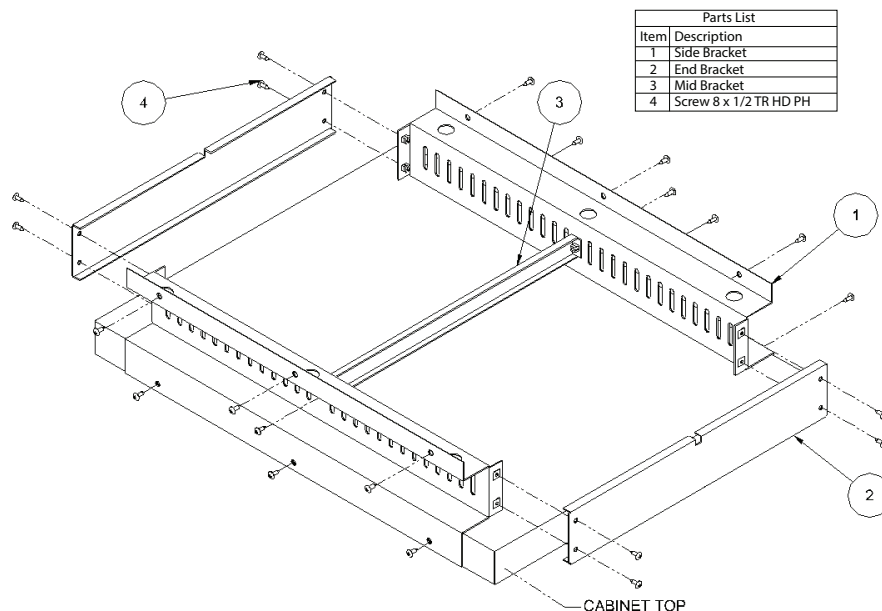

Buy Winston service parts online!
Factory direct at www.winstonparts.com